



EP-HWS-RCHP-200
EP-HWS-RCHP-200-1

EP-HWS-RCHP-200E
EP-HWS-RCHP-200E-1
(with backup electric heater)

EP-HWS-RCHP-300
EP-HWS-RCHP-300-1

EP-HWS-RCHP-300E
EP-HWS-RCHP-300E-1
(with backup electric heater)

SUPERBSOLAR HEAT PUMP AND TANK 200L, 300L AND OPTIONAL HEATER

SUPERBSOLAR Energy's hot water heat pumps provide energy-efficient hot water all year round. Our refrigerant cycling heat pumps are available with an optional built-in electric heater to boost hot water supply when needed.

The refrigerant cycling heat pump's heat exchanger is in the water tank resulting in less energy use due to heat loss. It can also operate under lower outdoor temperature conditions.

FEATURES

- Optional built-in electric heater as backup
- R134a refrigerant
- Max. water output temperature: 60°C
- Automatic startup and shutdown
- Four-way valve for automatic defrosting
- Anti-Legionella function
- Blue diamond enamel tank

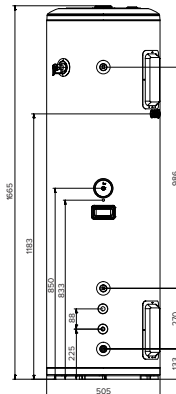
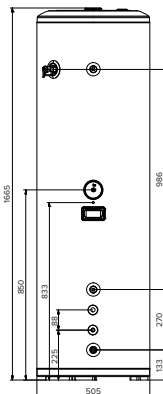
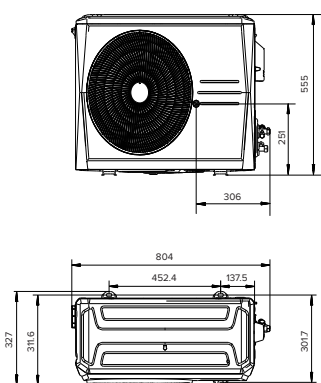
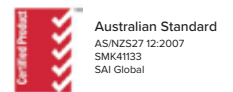

EP-HWS-RCHP-200
EP-HWS-RCHP-200-1
EP-HWS-RCHP-200E
EP-HWS-RCHP-200E-1

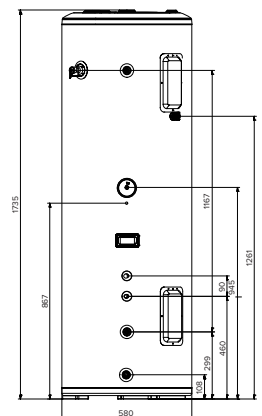
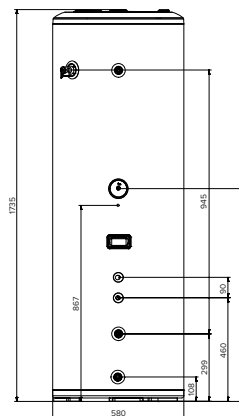

EP-HWS-RCHP-300
EP-HWS-RCHP-300-1
EP-HWS-RCHP-300E
EP-HWS-RCHP-300E-1